



**UNDERMOUNT GROUP**

**SPECIFICATION**

Seamless die-drawn construction of type 304, 18-8 stainless steel. Interior and top surfaces polished to a non-porous Hand-Blended Just Finish with highlighted bowl rim. Fully coated underside insulates for sound, and absorbs condensation. Conforms to ASME/ANSI A112.19.3M. Drain punch #35 for Just J-35 unless otherwise specified.

**UDX-1842-A**

**GENEROUS CAPACITY - DOUBLE COMPARTMENT  
DEEP - 18 GAUGE**

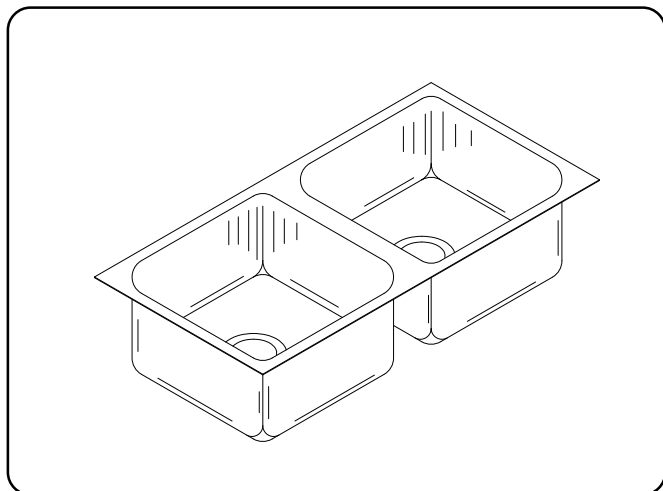
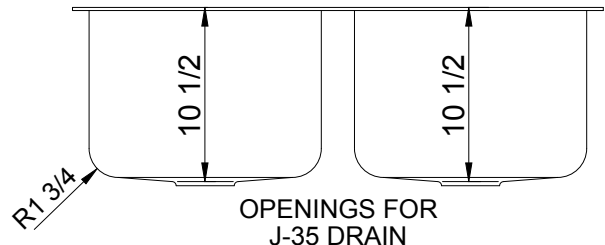
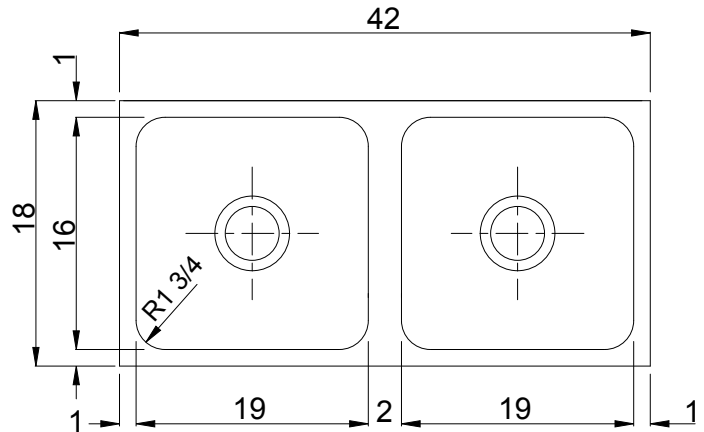

**SUBMITTAL DATA**

**27.02**

Gallon Capacity

**Capacity Matters**

Max ID sizing with straight sided bowl configuration (non tapered sides). Tight corner radius design.

APPROVED FOR MANUFACTURING

MODEL NO.: \_\_\_\_\_ QTY: \_\_\_\_\_  
 JOB NAME: \_\_\_\_\_  
 TAG/ITEM: \_\_\_\_\_  
 CUSTOMER: \_\_\_\_\_  
 SIGNATURE: \_\_\_\_\_



FUNCTIONAL DESIGN, QUALITY, AND SPECIFICATIONS LISTED DESCRIBE THE JUST STANDARD OF QUALITY. WHEN MAKING COMPARISONS WITH OTHER OFFERINGS, INSIST ON THE JUST QUALITY OF CONSTRUCTION. FOR ADDITIONAL INFORMATION REGARDING THE COMPLETE LINE OF **JUST SINKS, FAUCETS AND DRAINS**, VISIT OUR WEB SITE AT [www.justmfg.com](http://www.justmfg.com)

**JUST MANUFACTURING COMPANY**

9233 KING STREET . FRANKLIN PARK . ILLINOIS . 60131-2111

PH: 847-678-5150 . FAX: 847-678-6817

E-MAIL: [custserv@justmfg.com](mailto:custserv@justmfg.com) . [www.justmfg.com](http://www.justmfg.com)