



ACADEMIC GROUP



ADA COMPLIANT

SPECIFICATION

Seamless die-drawn construction of type 304, 18-8 stainless steel. Interior and top surfaces polished to a non-porous Hand-Blended Just Finish with highlighted bowl rim. Fully coated underside insulates for sound, and reduces condensation. Straight-sided compartment with 1 3/4" radius corners. Self-rimming top mount Grip-Rim Plus with 300 series stainless steel mounting channels. Drain punch #35 centered for Just J-35 unless otherwise specified.

CRB-ADA - SERIES - A - 18 GA.

A.D.A. COMPLIANT - CLASSROOM SINKS

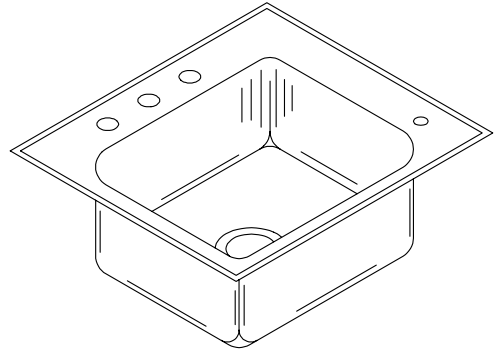

SUBMITTAL

DATA

To be specified :

Faucet hole punching:

- (1) Hole Centered
- (2) Holes on 4" centers
- (3) Holes on 4" centers (illustrated)

Alternate Punching:

Faucet Model: _____

Punching required: _____

Bubbler punching:

- (1) Hole -Right front (illustrated)

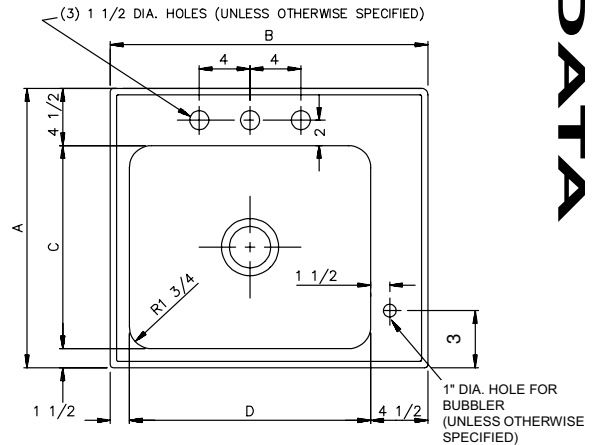

DRAIN LOCATION MUST BE SPECIFIED:

- CENTER (SHOWN)
- LEFT REAR
- RIGHT REAR
- CENTER REAR

LOCATIONS MUST BE A MINIMUM OF 4 1/2" FROM THE BOWL WALL.

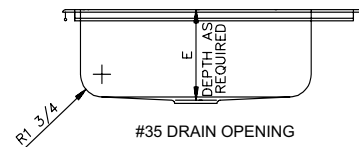

Job Name _____	
Customer _____	
Architect/Engineer _____	
APPROVED FOR MANUFACTURING	
MODEL NO. _____	QTY. _____
COMPANY _____	
TITLE _____	DATE _____
SIGNATURE _____	

MODEL NO.	A	B	C	D	E	CUTOUT*
CRB-ADA-2022-A-GR	20	22	14	16	4-1/2 to 6-1/2	19-1/4 x 21-1/4
CRB-ADA-2220-A-GR	22	20	16	14	4-1/2 to 6-1/2	21-1/4 x 19-1/4
CRB-ADA-2225-A-GR	22	25	16	19	4-1/2 to 6-1/2	21-1/4 x 24-1/4

* Cutout dimensions shown (Front-to-Back) x (Left-to-Right) - Corners of cutout may be square or up to 1/2" radius.

FUNCTIONAL DESIGN, QUALITY AND SPECIFICATIONS LISTED DESCRIBE THE JUST STANDARD OF QUALITY. WHEN MAKING COMPARISONS WITH OTHER OFFERINGS, INSIST ON THE JUST QUALITY OF CONSTRUCTION. FOR ADDITIONAL INFORMATION REGARDING THE COMPLETE LINE OF JUST SINKS, FAUCETS AND DRAINS, VISIT OUR WEB SITE AT www.justmfg.com

JUST MANUFACTURING COMPANY	
9233 KING STREET . FRANKLIN PARK . ILLINOIS . 60131-2111	
PH: 847-678-5150 . FAX: 847-678-6817	
E-MAIL: custserv@justmfg.com . www.justmfg.com	

REVISED 4/2009