



# CONGENIALITY GROUP

## SPECIFICATION

Seamless die-drawn construction of type 304, 18-8 stainless steel. Interior and top surfaces polished to a non-porous Hand-blended Just Finish with highlighted bowl rim. Fully coated underside insulates for sound, and reduces condensation. Straight-sided compartment with 1 3/4" radius corners provides greater capacity. Self-rimming top mount Grip-Rim Plus with 300 series stainless steel mounting channels. Conforms to ASME/ANSI A112.19.3M. Drain punch #15 centered for Just J-15 unless otherwise specified.

### INCLUDES:

- NuTone built-in blender with under counter power unit, blender jar and lid.

### To be specified :

- Faucet hole punching:
- (1) Hole Centered(illustrated)
- (2) Holes on 4" centers
- (3) Holes on 4 "centers
- (4) Holes
- Alternate Punching:  
Faucet Model: \_\_\_\_\_  
Punching required: \_\_\_\_\_

FUNCTIONAL DESIGN, QUALITY, AND SPECIFICATIONS LISTED DESCRIBE THE JUST STANDARD OF QUALITY. WHEN MAKING COMPARISONS WITH OTHER OFFERINGS, INSIST ON THE JUST QUALITY OF CONSTRUCTION. FOR ADDITIONAL INFORMATION REGARDING THE COMPLETE LINE OF **JUST** SINKS, FAUCETS AND DRAINS, VISIT OUR WEB SITE AT [www.justmfg.com](http://www.justmfg.com)

|                          |
|--------------------------|
| Job Name _____           |
| Customer _____           |
| Architect/Engineer _____ |

## BS-1525-A-GR-R-NT

### SINGLE BOWL-BLENDER SINK

## NO LONGER AVAILABLE

|                   |                       |
|-------------------|-----------------------|
| BS-1525-A-GR-R-NT | CUTOUT<br>DIMENSIONS* |
|                   | 14-1/4 x 24-1/4       |

\* Cutout dimensions shown (Front-to-Back) x (Left-to-Right) - corners of cutout may be square or any radius up to 1/2".

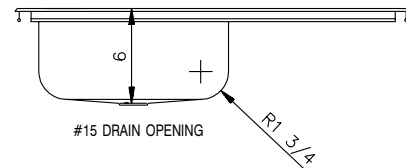
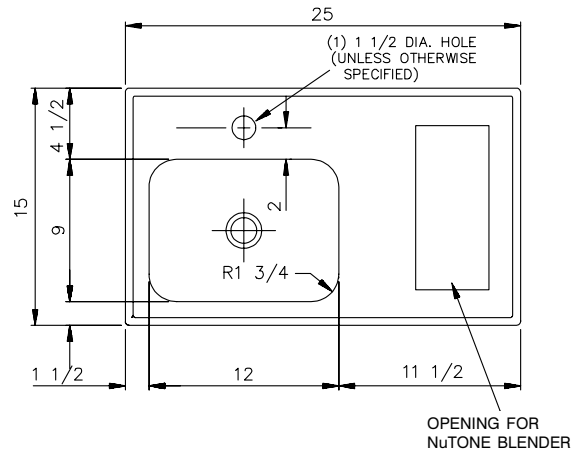

|                            |            |
|----------------------------|------------|
| APPROVED FOR MANUFACTURING |            |
| MODEL NO. _____            | QTY. _____ |
| COMPANY _____              |            |
| TITLE _____                | DATE _____ |
| SIGNATURE _____            |            |

**SUBMITTAL DATA**

REVISED-5/2003