

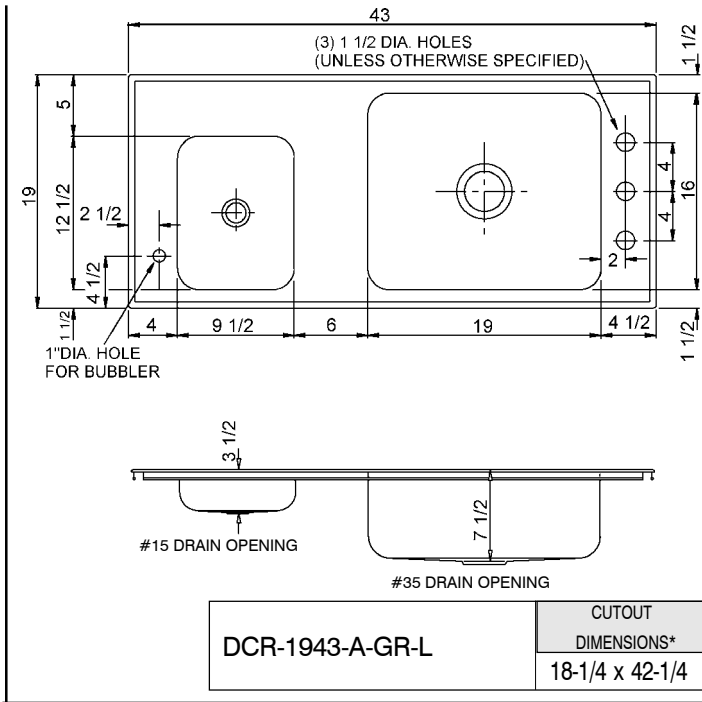

ACADEMIC GROUP

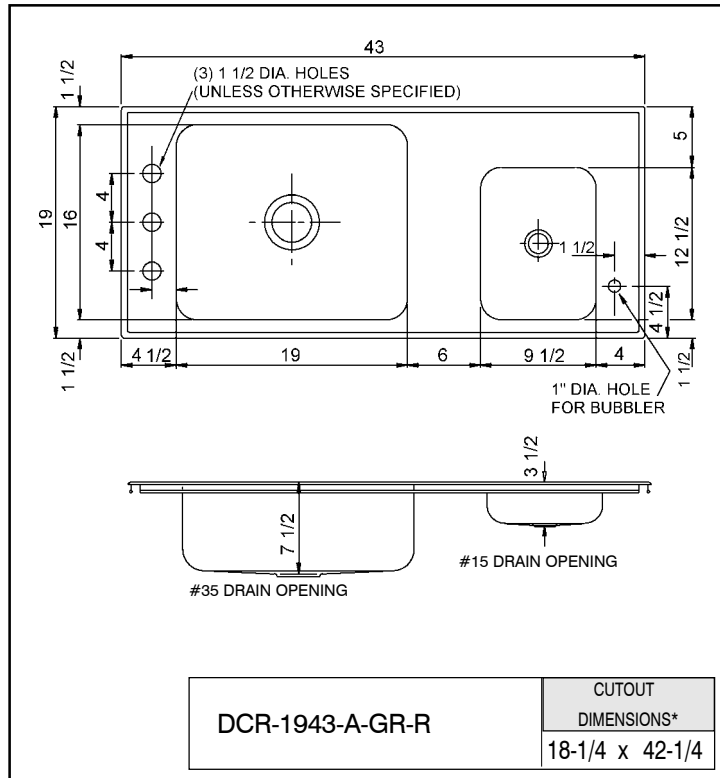

* Cutout dimensions shown (Front-to-Back) x (Left-to-Right) - Corners of cutout may be square or up to 1/2" radius.



* Cutout dimensions shown (Front-to-Back) x (Left-to-Right) - Corners of cutout may be square or up to 1/2" radius.

FUNCTIONAL DESIGN, QUALITY, AND SPECIFICATIONS LISTED DESCRIBE THE JUST STANDARD OF QUALITY. WHEN MAKING COMPARISONS WITH OTHER OFFERINGS, INSIST ON THE JUST QUALITY OF CONSTRUCTION. FOR ADDITIONAL INFORMATION REGARDING THE COMPLETE LINE OF JUST SINKS, FAUCETS AND DRAINS, VISIT OUR WEB SITE AT www.justmfg.com

JUST MANUFACTURING COMPANY
 9233 KING STREET . FRANKLIN PARK . ILLINOIS . 60131-2111
 PH: 847-678-5150 . FAX: 847-678-6817
 E-MAIL: custserv@justmfg.com . www.justmfg.com

DCR-1943 - SERIES - A - 18 GA.

CLASSROOM SINK & DRINKING FOUNTAIN COMBINATION

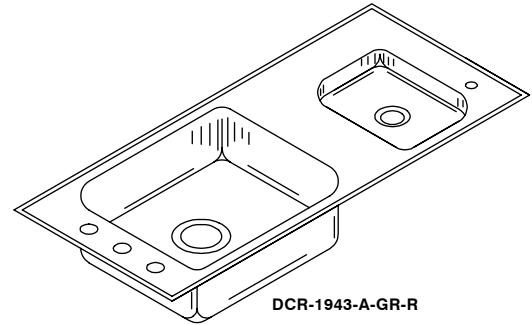

DCR-1943-A-GR-R



**AVAILABLE
ADA COMPLIANT**

SPECIFICATION

Seamless die-drawn construction of type 304, 18-8 stainless steel. Interior and top surfaces polished to a non-porous Hand-Blended Just Finish, with a highlighted bowl rim. Fully coated underside insulates for sound, and reduces condensation. Straight-sided compartment with 1 3/4" radius corners provides greater capacity. Self-rimming top mount Grip-Rim Plus with 300 series stainless steel mounting channels. Conforms to ASME/ANSI A112.19.3M. Drain punch #35 for Just J-35, and #15 for Just J-15-FS unless otherwise specified.

Faucet hole punching:

- (1) Hole Centered
- (2) Holes on 4" centers
- (3) Holes on 4" centers (illustrated) on Right
- (4) Holes

Bubbler punching:

- (1) Hole -Left front (see top left) for Drinking Fountain on Left
- (1) Hole -Right front (see lower left) for Drinking Fountain

Alternate Punching:

Faucet Model: _____

Punching required: _____

Job Name _____

Customer _____

Architect/Engineer _____

APPROVED FOR MANUFACTURING

MODEL NO. _____ QTY. _____

COMPANY _____

TITLE _____ DATE _____

SIGNATURE _____

REVISED-5/2004

SUBMITTAL DATA