



ACADEMIC GROUP

SPECIFICATION

Seamless die-drawn construction of type 304, 18-8 stainless steel. Interior and top surfaces polished to a non-porous Hand-Blended Just Finish with highlighted bowl rim. Fully coated underside insulates for sound, and reduces condensation. Straight-sided compartment with $1\frac{3}{4}$ " radius corners provides greater capacity. Self-rimming top mount Grip-Rim Plus with 300 series stainless steel mounting channels. Conforms to ASME/ANSI A112.19.3M. Drain punch #35 centered for Just J-35 unless otherwise specified.



**AVAILABLE
ADA COMPLIANT**

To be specified :

Faucet hole punching:

- (1) Hole Centered
- (2) Holes on 4" centers
- (3) Holes on 4" centers (illustrated)
- (4) Holes on 4" centers
- Alternate Punching:

Faucet Model: _____

Punching required: _____

Bubbler punching:

- (1) Hole -Right front (illustrated)

FUNCTIONAL DESIGN, QUALITY, AND SPECIFICATIONS LISTED DESCRIBE THE JUST STANDARD OF QUALITY. WHEN MAKING COMPARISONS WITH OTHER OFFERINGS, INSIST ON THE JUST QUALITY OF CONSTRUCTION. FOR ADDITIONAL INFORMATION REGARDING THE COMPLETE LINE OF **JUST** SINKS, FAUCETS AND DRAINS, VISIT OUR WEB SITE AT www.justmfg.com

Job Name _____

Customer _____

Architect/Engineer _____

CRB - SERIES - A - 18 GA.

CLASSROOM SINKS

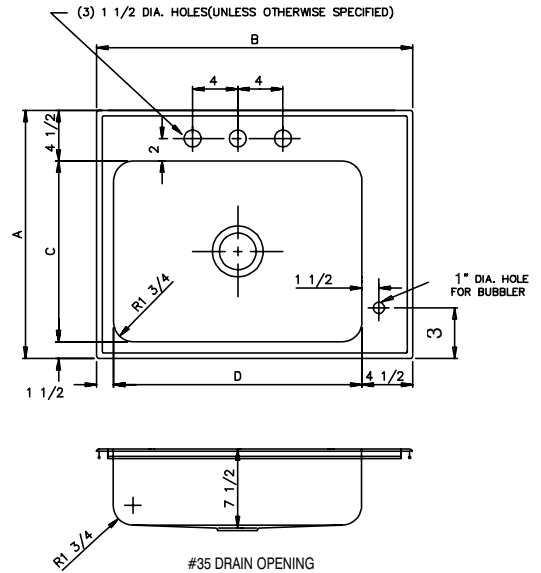
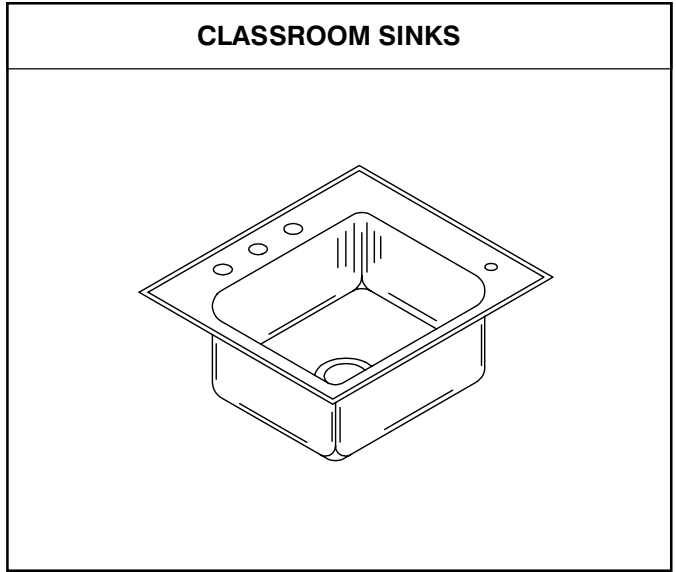

MODEL NO.	A	B	C	D	CUTOUT*
CRB-2022-A-GR	20	22	14	16	19-1/4 x 21-1/4
CRB-2220-A-GR	22	20	16	14	21-1/4 x 19-1/4
CRB-2225-A-GR	22	25	16	19	21-1/4 x 24-1/4
CRB-2228-A-GR	22	28	16	22	21-1/4 x 27-1/4

* Cutout dimensions shown (Front-to-Back) x (Left-to-Right) - Corners of cutout may be square or up to 1/2" radius.

APPROVED FOR MANUFACTURING

MODEL NO. _____ QTY. _____

COMPANY _____

TITLE _____ DATE _____

SIGNATURE _____

REVISED 4/2009

JUST MANUFACTURING COMPANY

9233 KING STREET . FRANKLIN PARK . ILLINOIS . 60131-2111

PH: 847-678-5150 . FAX: 847-678-6817 . E-MAIL: custserv@justmfg.com . www.justmfg.com

SUBMITTAL DATA