



**ACADEMIC GROUP**

**SPECIFICATION**

Seamless die-drawn construction of type 304, 18-8 stainless steel. Interior and top surfaces polished to a non-porous Hand-Blended Just Finish with highlighted bowl rim. Fully coated underside insulates for sound, and reduces condensation. Straight-sided compartment with 1 3/4" radius corners provides greater capacity. Self-rimming top mount Grip-Rim Plus with 300 series stainless steel mounting channels. Conforms to ASME/ANSI A112.19.3M. Drain punch #35 centered for Just J-35 unless otherwise specified.

**CRA - SERIES - A - 18 GA.**

**CLASSROOM SINKS**

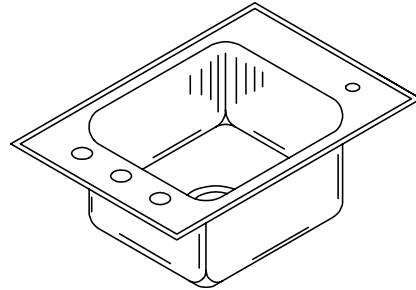

**SUBMITTAL**

**DATA**



**AVAILABLE  
ADA COMPLIANT**

**To be specified :**

**Faucet hole punching:**

- (1) Hole -Left rear
- (1) Hole -Right rear
- (1) Hole Centered
- (2) Holes on 4" centers
- (3) Holes on 4 "centers(illustrated)

**Bubbler punching:**

- (1) Hole -Right front(illustrated)
- (1) Hole -Left front

Alternate Punching:

Faucet Model: \_\_\_\_\_

Punching required: \_\_\_\_\_

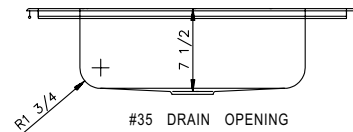
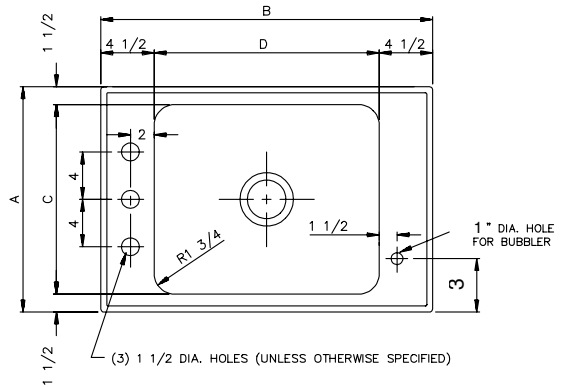

MODEL NO.	A	B	C	D	CUTOUT*
CRA-1725-A-GR	17	25	14	16	16-1/4 x 24-1/4
CRA-1923-A-GR	19	23	16	14	18-1/4 x 22-1/4
CRA-1928-A-GR	19	28	16	19	18-1/4 x 27-1/4
CRA-1931-A-GR	19	31	16	22	18-1/4 x 30-1/4
CRA-2225-A-GR	22	25	19	16	21-1/4 x 24-1/4

\* Cutout dimensions shown (Front-to-Back) x (Left-to-Right) - Corners of cutout may be square or up to 1/2" radius.

FUNCTIONAL DESIGN, QUALITY, AND SPECIFICATIONS LISTED DESCRIBE THE JUST STANDARD OF QUALITY. WHEN MAKING COMPARISONS WITH OTHER OFFERINGS, INSIST ON THE JUST QUALITY OF CONSTRUCTION. FOR ADDITIONAL INFORMATION REGARDING THE COMPLETE LINE OF **JUST** SINKS, FAUCETS AND DRAINS, VISIT OUR WEB SITE AT [www.justmfg.com](http://www.justmfg.com)

Job Name \_\_\_\_\_

Customer \_\_\_\_\_

Architect/Engineer \_\_\_\_\_

APPROVED FOR MANUFACTURING

MODEL NO. \_\_\_\_\_ QTY. \_\_\_\_\_

COMPANY \_\_\_\_\_

TITLE \_\_\_\_\_ DATE \_\_\_\_\_

SIGNATURE \_\_\_\_\_

REVISED 4/2009

**JUST MANUFACTURING COMPANY**

9233 KING STREET . FRANKLIN PARK . ILLINOIS . 60131-2111

PH: 847-678-5150 . FAX: 847-678-6817 . E-MAIL: [custserv@justmfg.com](mailto:custserv@justmfg.com) . [www.justmfg.com](http://www.justmfg.com)