

SLX - SERIES - A - 18 GA.

SPACE SAVER - EXTRA DEEP
LEDGE TYPE - SINGLE BOWL

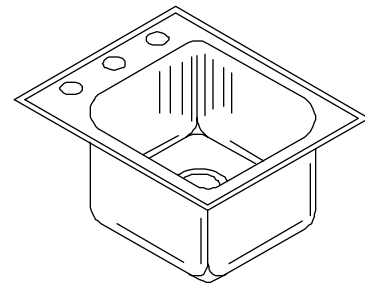

SPECIFICATION

Seamless die-drawn construction of type 304, 18-8 stainless steel. Interior and top surfaces polished to a non-porous Hand-Blended Just Finish with highlighted bowl rim. Fully coated underside insulates for sound, and reduces condensation. Straight-sided compartment with $1\frac{3}{4}$ " radius corners provides greater capacity. Self-rimming top mount Grip-Rim Plus with 300 series stainless steel mounting channels. Conforms to ASME/ANSI A112.19.3M. Drain punch #35 centered for Just J-35 unless otherwise specified.

TYPE 316 STAINLESS STEEL(check if applicable)

To be specified :

■ Faucet hole punching:

(1) Hole Centered

(2) Holes on 4" centers

(3) Holes on 4 "centers(illustrated)

Alternate Punching:

Faucet Model: _____

Punching required: _____

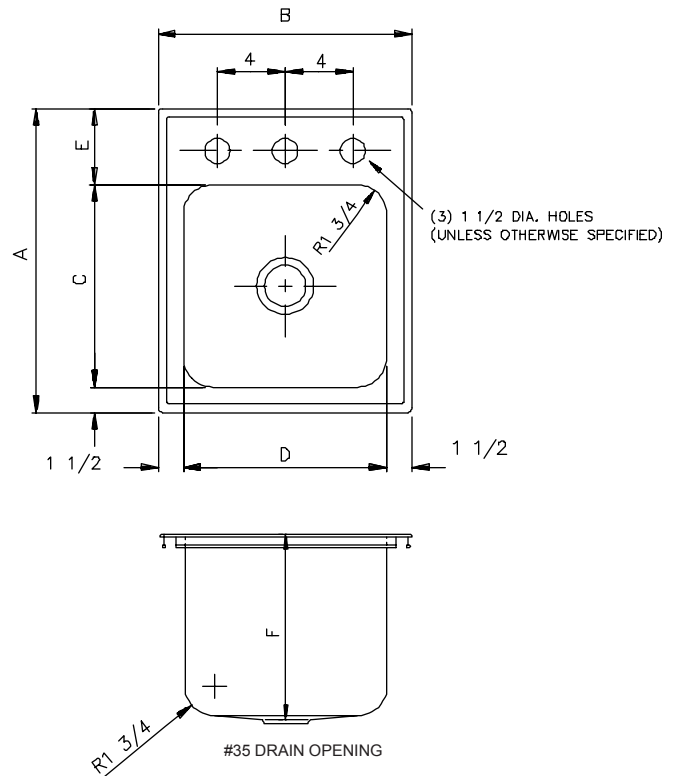

FUNCTIONAL DESIGN, QUALITY, AND SPECIFICATIONS LISTED DESCRIBE THE JUST STANDARD OF QUALITY. WHEN MAKING COMPARISONS TO OTHER OFFERINGS, INSIST ON THE JUST QUALITY OF CONSTRUCTION.

Job Name _____
Customer _____
Architect/Engineer _____
APPROVED FOR MANUFACTURING
MODEL NO. _____ QTY. _____
COMPANY _____
TITLE _____ DATE _____
SIGNATURE _____

MODEL NO.	A	B	C	D	E	F	CUTOUT*
SLX-1617-A-GR	16	17	10	14	4-1/2	10	15-1/4 x 16-1/4
SLX-1815-A-GR	18	15	12	12	4-1/2	9	17-1/4 x 14-1/4
SLX-1921-A-GR	19	21	14	18	3-1/2	10-1/2	18-1/4 x 20-1/2
SLX-2017-A-GR	20	17	14	14	4-1/2	10-1/2	19-1/4 x 16-1/4
SLX-2019-A-GR	20	19	14	16	4-1/2	10-1/2	19-1/4 x 18-1/4

* Cutout dimensions shown (Front-to-Back) x (Left-to-Right) - corners may be square or up to 1/2" radius.

Just MANUFACTURING COMPANY
9233 KING STREET, FRANKLIN PARK, ILLINOIS 60131
PHONE: (847) 678-5150 FAX: (847) 678-6817

SUBMITTAL

DATA