



CONTINENTAL GROUP

SPECIFICATION

Seamless die-drawn construction of type 304, 18-8 stainless steel. Interior and top surfaces polished to a non-porous Hand-Blended Just Finish with highlighted bowl rim. Fully coated underside insulates for sound, and reduces condensation. Straight-sided compartment with $2\frac{3}{4}$ " radius corners provides greater capacity. Self-rimming top mount Grip-Rim Plus with 300 series stainless steel mounting channels. Conforms to ASME/ANSI A112.19.3M. Drain punch #35 centered for Just J-35 unless otherwise specified.

CCRA-1725-B-GR - 20 GA.

CLASSROOM SINK

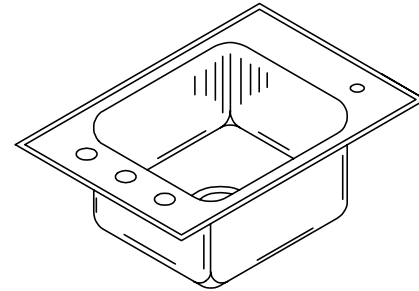

CCRA-1725-B-GR

CUTOUT
DIMENSIONS*
16-1/4 x 24-1/4

* Cutout dimensions shown (Front-to-Back) x (Left-to-Right) - corners of cutout may be square or any radius up to 1/2".

SUBMITTAL DATA

To be specified :

■ Faucet hole punching:

- (1) Hole -Left rear
- (1) Hole -Right rear
- (1) Hole Centered
- (2) Holes on 4" centers
- (3) Holes on 4 "centers(illustrated)

□ Alternate Punching:

Faucet Model: _____

Punching required: _____

■ Bubbler punching:

- (1) Hole -Right front(illustrated)
- (1) Hole -Left front

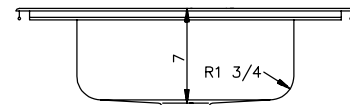
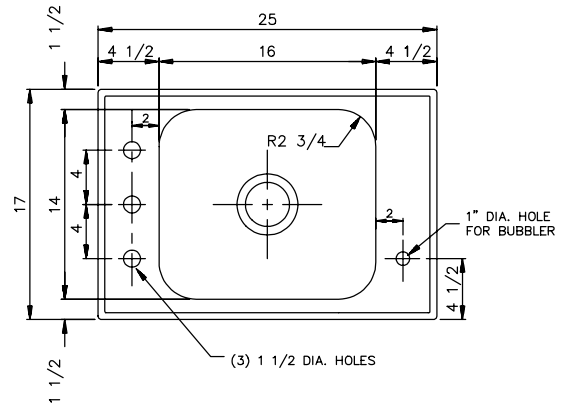

#35 DRAIN OPENING

JUST MFG. COMPANY CONTINUES TO MAKE QUALITY AND FUNCTIONALITY A MARK OF THE JUST PRODUCT LINE. TO DO SO REQUIRES THAT WE RESERVE THE RIGHT TO CHANGE PRODUCT INFORMATION WITHOUT NOTICE. DIMENSIONS MAY VARY AND ARE SUBJECT TO CHANGE WITHOUT NOTICE. NO RESPONSIBILITY IS ASSUMED FOR USE OF SUPERCEDED OR VOIDED DATA. FOR THE MOST CURRENT AND ACCURATE INFORMATION REGARDING THE COMPLETE LINE OF JUST SINKS, FAUCETS AND DRAINS, CLICK ON THE **SPEC LINE DRAWINGS** LINK ON OUR WEB SITE AT www.justmfg.com

Job Name _____

Customer _____

Architect/Engineer _____

APPROVED FOR MANUFACTURING

MODEL NO. _____ QTY. _____

COMPANY _____

TITLE _____ DATE _____

SIGNATURE _____

REVISED-5/2004

JUST MANUFACTURING COMPANY

9233 KING STREET . FRANKLIN PARK . ILLINOIS . 60131-2111

PH: 847-678-5150

FAX: 847-678-6817

E-MAIL: custserv@justmfg.com

www.justmfg.com